

Illustrated Parts-Breakdown

CSV-2515 Customer Assembly Components

The components identified below are provided with a new chipper and must be assembled by the customer. Refer to the Parts List, provided on page 5, to see the part number and part description that corresponds to the balloon numbers found in this illustration.

⚠ WARNING

Serious personal injury to the operator or bystanders, as well as damage to equipment and property, can occur, if all safety and assembly instructions, provided with this product, are not followed.

This illustration is provided solely for the purposes of easy part identification, when ordering replacement parts. Refer to the assembly instructions, provided, for proper assembly procedures.

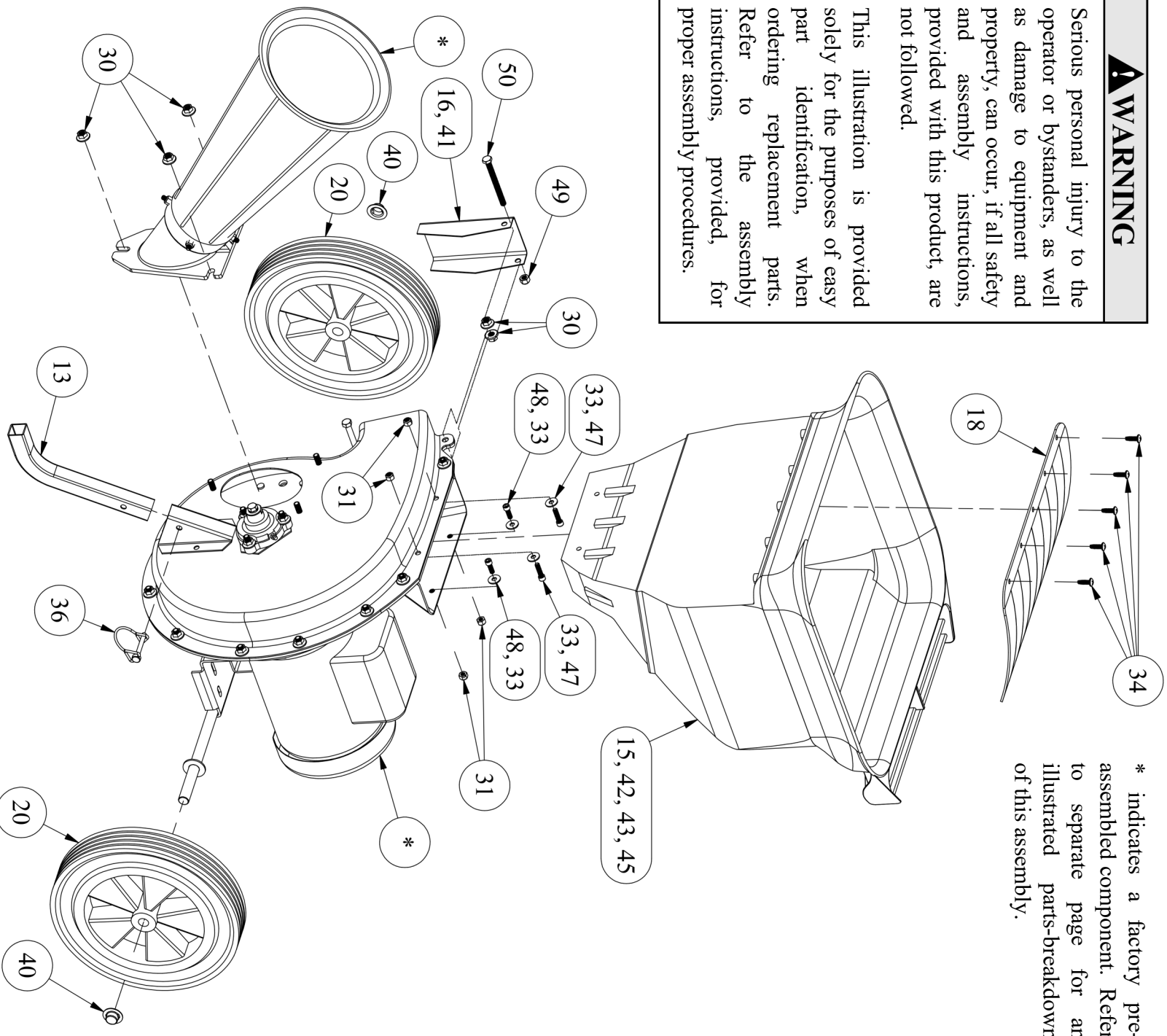

! WARNING

Serious personal injury to the operator or bystanders, as well as damage to equipment and property, can occur, if all safety and assembly instructions, provided with this product, are not followed.

This illustration is provided solely for the purposes of easy part identification, when ordering replacement parts. Refer to the assembly instructions, provided, for proper assembly procedures.

The components identified below are part of the factory pre-assembled lower unit assembly. Refer to the Parts List, provided on page 5, to see the part number and part description that corresponds to the balloon numbers found in this illustration.

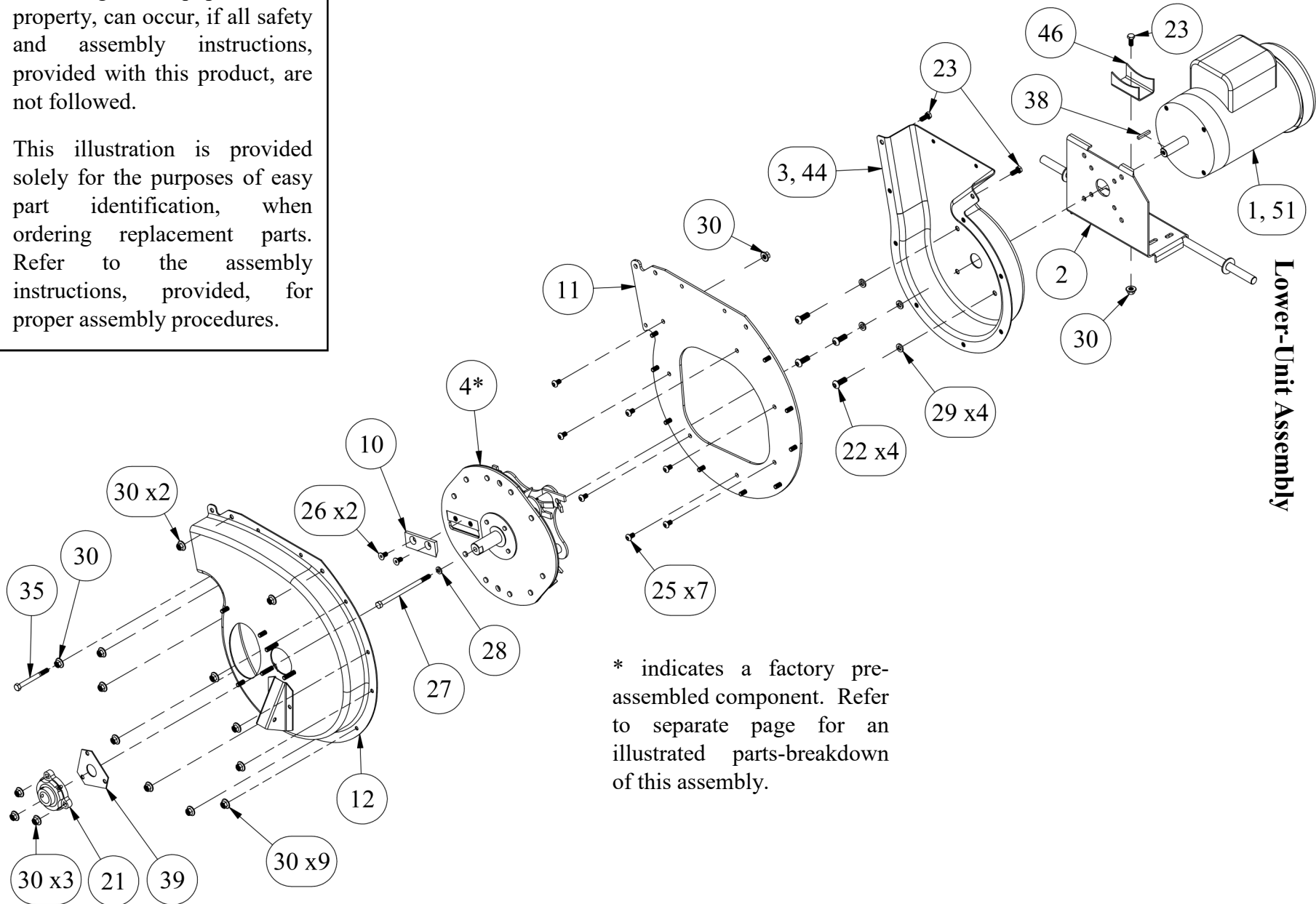

* indicates a factory pre-assembled component. Refer to separate page for an illustrated parts-breakdown of this assembly.

Illustrated Parts-Breakdown

Lower-Unit Assembly

Illustrated Parts-Breakdown

Chipper-Cone Assembly

⚠ WARNING

Serious personal injury to the operator or bystanders, as well as damage to equipment and property, can occur, if all safety and assembly instructions, provided with this product, are not followed.

This illustration is provided solely for the purposes of easy part identification, when ordering replacement parts. Refer to the assembly instructions, provided, for proper assembly procedures.

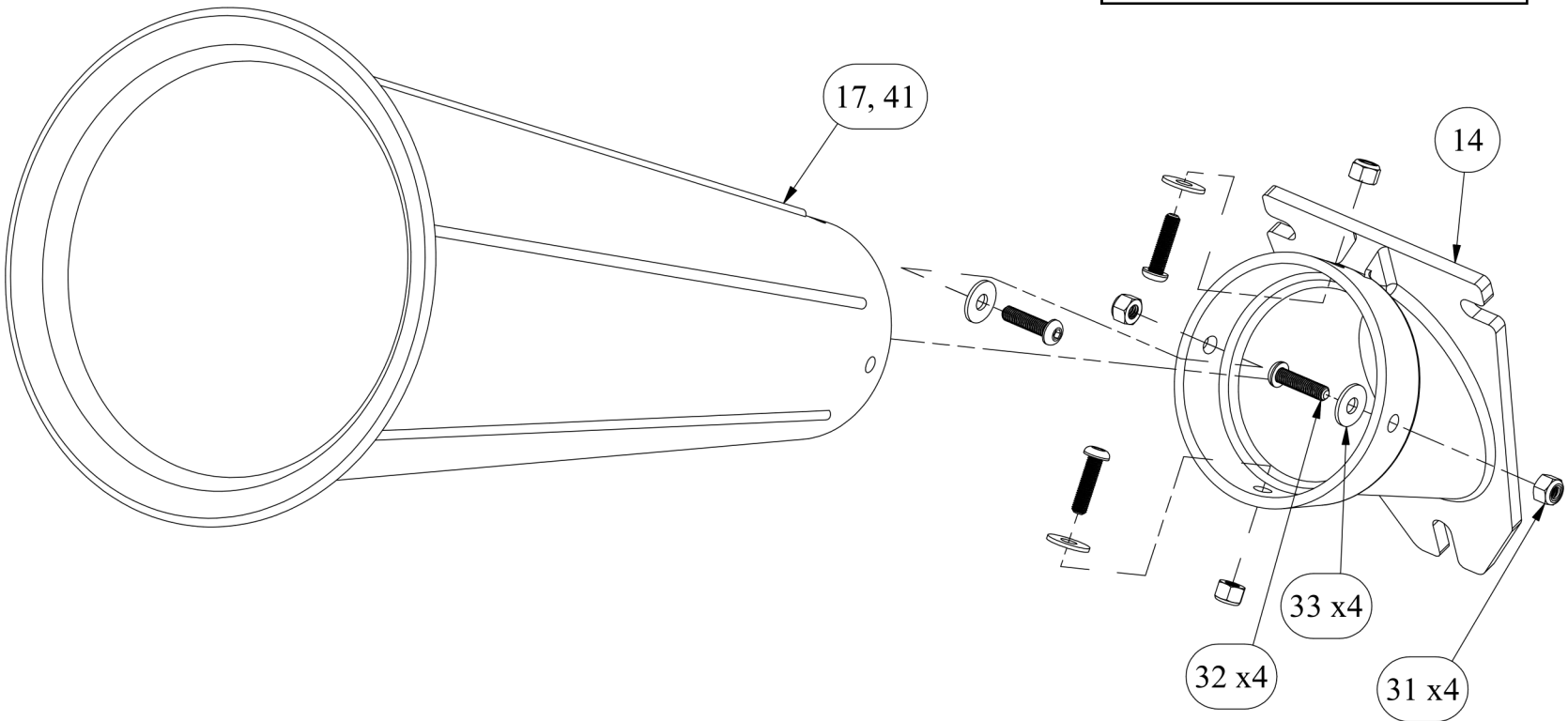

The components identified below are part of the factory pre-assembled chipper cone assembly. Refer to the Parts List, provided on page 5, to see the part number and part description that corresponds to the balloon numbers found in this illustration.

! WARNING

Serious personal injury to the operator or bystanders, as well as damage to equipment and property, can occur, if all safety and assembly instructions, provided with this product, are not followed.

This illustration is provided solely for the purposes of easy part identification, when ordering replacement parts. Refer to the assembly instructions, provided, for proper assembly procedures.

The components identified below are part of the factory pre-assembled rotor assembly. Refer to the Parts List, provided on page 5, to see the part number and part description that corresponds to the balloon numbers found in this illustration.

The complete rotor assembly, Balloon 4, comes factory pre-assembled, with all of the items depicted. *Note: It **does not** include a chipper-knife.*

The y-hammer components, everything depicted except Balloon 4, are only sold as a complete kit.

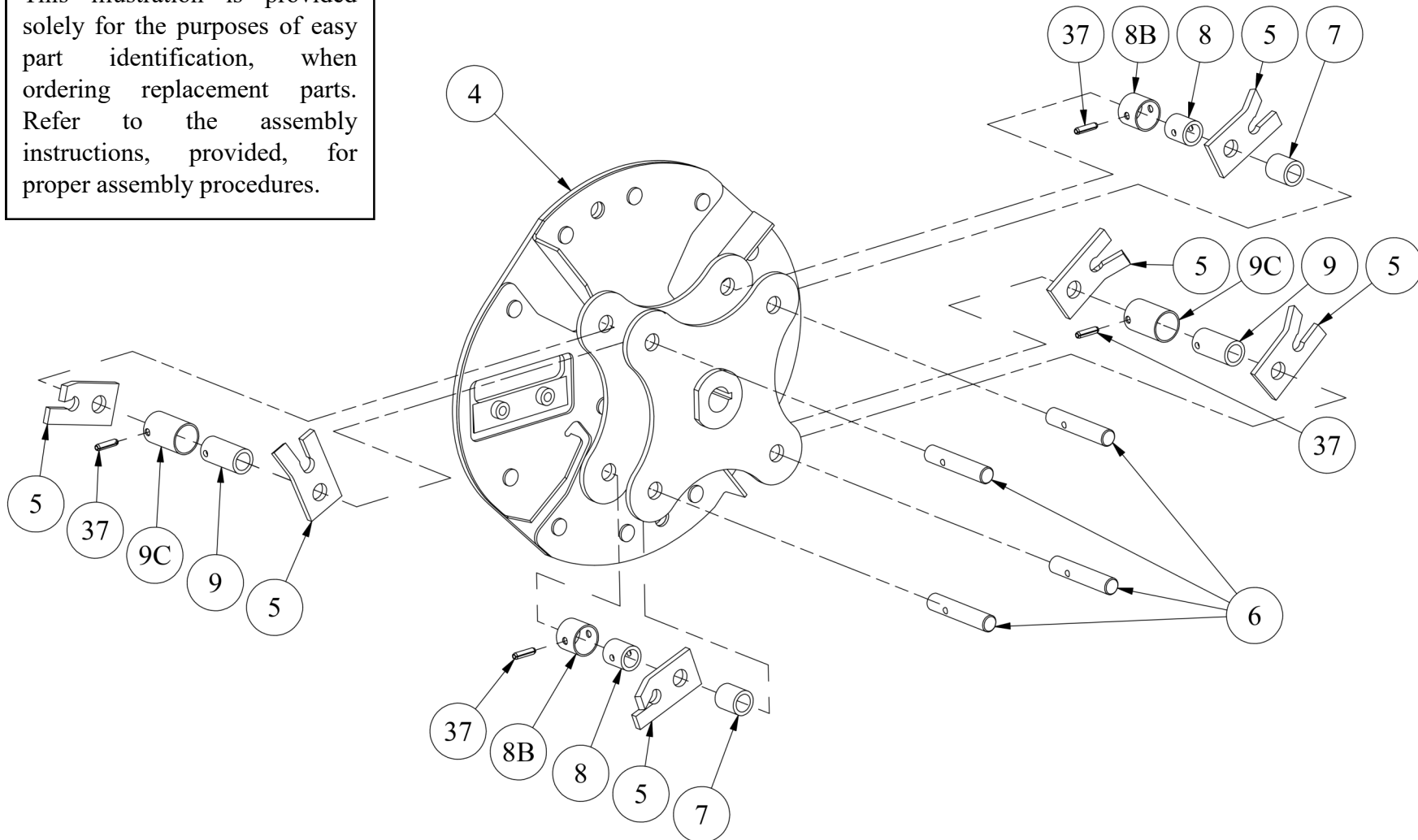

Illustrated Parts-Breakdown **CSV-2515 Rotor Assembly**

Illustrated Parts-Breakdown

CSV-2515 Detailed Parts List

The "Ill. #" refers to the balloon numbers in the Illustrated Parts-Breakdown illustrations. Refer to both the "Part #" and "Description" when ordering. The "Qty" refers to the total number of each part, used in the assembly of the chipper shredder. Items without an "Ill. #" are available, but are not shown in the illustrations.

Ill. #	Part #	Description	Qty
28	705620005	Lock washer, split ring, 5/16	1
29	716620005	Lock washer, split ring, 3/8	4
30	705320005	SFN, 5/16-18	22
31	888000042	NILN, 1/4-20	8
32	888000028	BHSCS, 1/4-20 x 1	4
33	710620005	Flat washer, USS, 1/4	8
34	700020005	TFSPPH, 14 x 3/4	5
35	717520005	HHCS, 5/16-18 x 3 1/4	1
36	710220005	Lynch pin	1
37	703200005	Roll pin, 3/16 x 3/4	4
38	763100002	Key, Woodruff, #9, 3/16 x 3/4	1
38	888000254	Key, 3/16" sq. x 1 1/4"	1
39	888000193	Greasable bearing shield	1
40	709920005	Push nut, 5/8"	2
41	800070435V	Decal, CSV, danger, vertical	2
42	800070445	Decal, caution, 4" x 9.625"	1
43	800070435H	Decal, CSV, danger, horizontal	1
44	800070455	Decal, serial number	1
45	800070832	Decal, CSV, size limit, 1/2"	1
46	111010802	Motor support bracket	1
47	888000136	SHCS, 1/4-20 x 3/4	2
48	888000137	SHCS, 1/4-20 x 1	2
49	888000055	NILN, 5/16-18	1
50	888000037	HHTB, 5/16-18 x 3 1/2	1
51	800070442	Decal, CSV, electric motor	1
-	888000230	Allen wrench, 3/16, 6" arm	1
-	719050005	Allen wrench, 5/32	1
-	700000005	Safety goggles	1

Ill. #	Part #	Description	Qty
1	825150002	Motor, 1.5 hp, 115 v/60 hz/1 ph	1
2	888000210	Engine mount/axle	1
3	302010212	Grinder housing, electric	1
4	308000792	Rotor, electric w/3/4" bore	1
5	103009035	Y-hammer	6
6	204009042	Y-hammer shaft, electric	4
7	211009075	Spacer A (short, plain)	2
8	211009055	Spacer B (short, w/hole)	2
8B	265001895	Roll pin sleeve B	2
9	211009355	Spacer C (long, w/hole)	2
9C	265001905	Roll pin sleeve C	2
10	810009015	Chipper knife	1
11	303010232	Center plate, 12"	1
12	302010252	Fan housing, 12"	1
13	888000179	Leg	1
14	400010365	Chipper cone casting	1
15	500050515	Shredder hopper, black	1
16	113010395	Discharge deflector	1
17	500050375	Chipper cone, black	1
18	114000345	Shredder hopper guard	1
-	700060405	Collection bag, std, 24" x 36"	1
20	709040005	Wheel, 12"	2
21	888000194	Bearing, 1" bore, greasable	1
22	888000233	BHSCS, 3/8-16 x 1	4
23	705520005	HHCS, 5/16-18 x 3/4	3
24	-	-	-
25	705720005	BHSCS, 5/16-18 x 1/2	7
26	706850005	FHSCS, 5/16-24 x 5/8	2
27	888000079	HHCS, 5/16-24 x 5 1/2	1